

Build anything with

QUBELOK

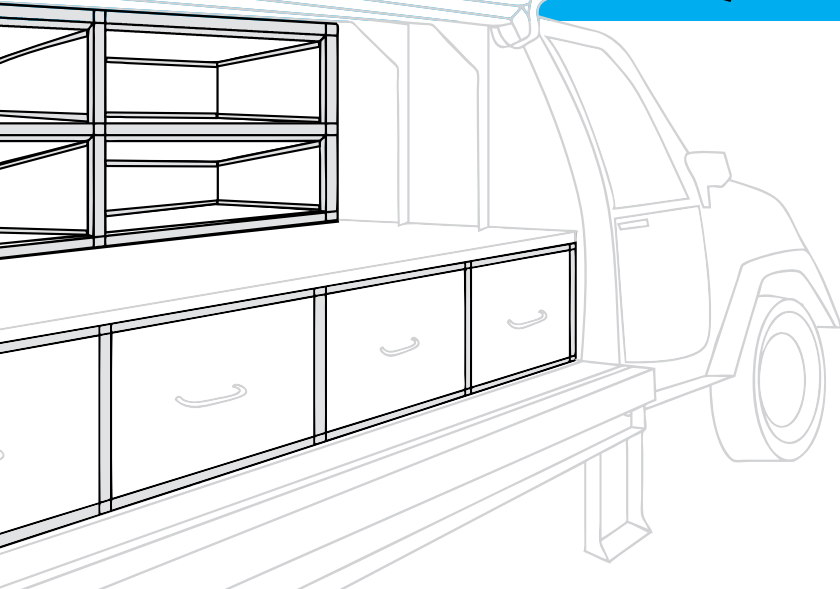

The Qubelok system lets you design and create your own storage, display furniture and items for domestic or office use. Qubelok's strength and light weight gives you unlimited design options. Available in a range of colours and with a variety of accessories, the only limit is your imagination!

Shapes

Versatile, solid geometric combinations.
Solid geometric shapes like those ticked below are the strongest.
Connecting cube shapes make the strongest units.

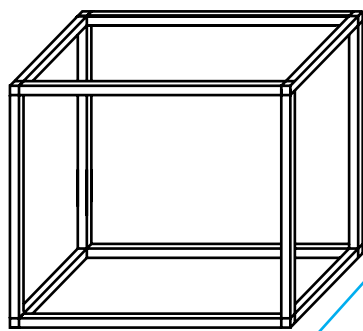

Cube shapes are very strong.

There should be no unsupported horizontals. (cantilevers)

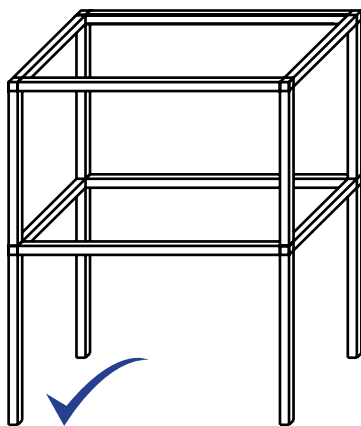
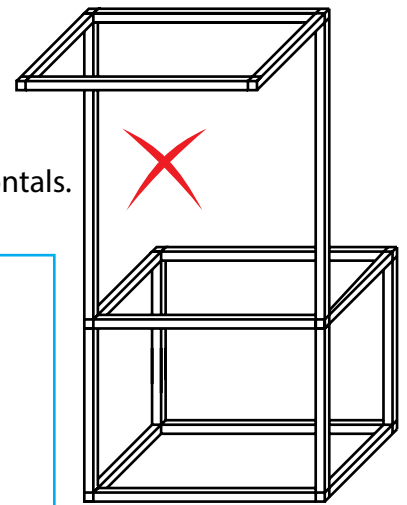

Longer legs need a stiffening cross member.

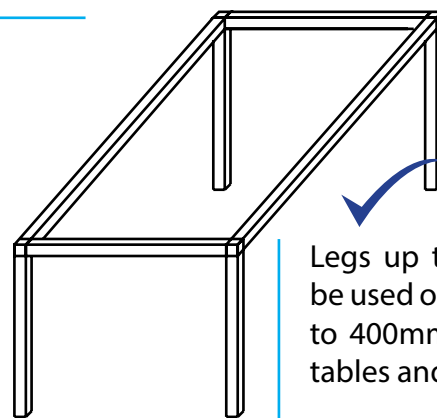

Legs up to 300mm long may be used on most structures. Up to 400mm long on light duty tables and stands.

Usually all joints should be supported by downward struts

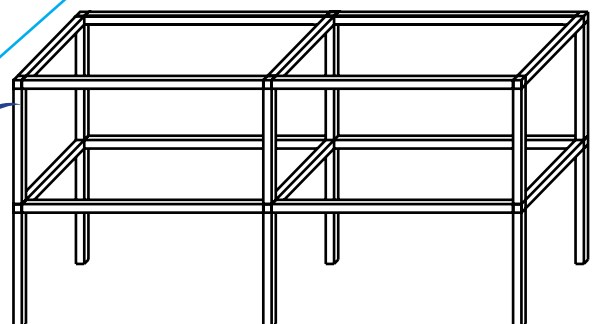

Shelving

Qubelok Sections

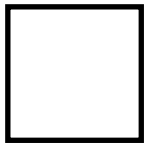

QUB-STD

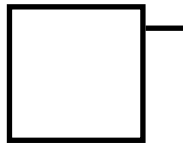

QUB-1L

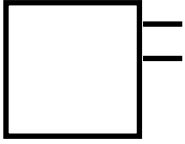

QUB-REC7.5

7.5mm Receptor

Qubelok has lipped tubing (QUB1L) available which allows you to inset timber or glass shelving to suit your needs. Flip the tubing over to create a low or high set lip for a flush finish.

TIMBER Shelves or table tops of 17mm timber or particle board fit neatly on the low set lip support.

GLASS When fitting glass or perspex, turn the lipped tubing over to set the lip high for a 6mm thickness.

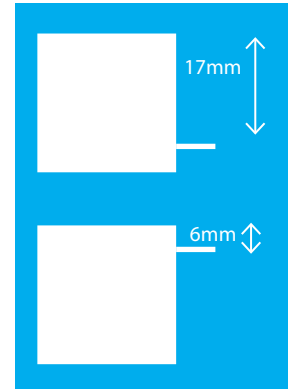

Accessories and Connectors

Castors - Fit precisely and securely into the tubing to make items easy to move around.

End Cap - Finish off legs and prevent scuffing on your tile, carpet or timber flooring.

Qubelok Extrusions are available in mill finish, clear or black anodised, or custom order any colour.

Choose from seven different **Qubelok connectors** to create any number of combinations



QUB P20



QUB P30



QUB P31



QUB P40



QUB P41



QUB P50



QUB P60



QUB End Cap



QUB P13
(wheel only)



QUB P15
(fits wheel)



QUB
Adjustable Foot
(male thread)



Cap For
Adjustable Foot
(female thread)

Designing

The graph below shows acceptable loads on maximum supported spans.

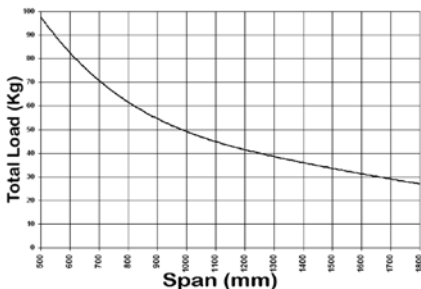

Span

To increase the strength of your design, simply add another vertical support.

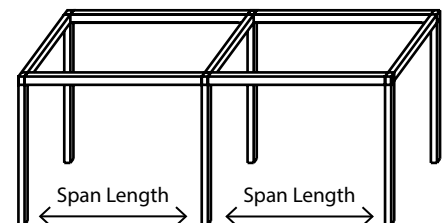
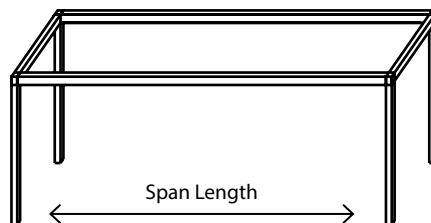

aluminium trade centre

Noble Park: Unit 4 / 556-598 Princes Hwy

Carrum Downs: 3 Industry Boulevard

(03) 9544 6659

www.aluminiumtc.com.au